

- v.1.4.1
- R5,R6,C29,C30 values fixed
- powerbutton connection fixed
- v.1.4.2
- USB host connector error
- Analog and RAM on separate sheet
- v.1.4.3
- XRESET pull up error
- Crystal ground error
- Power button capacitor value error
- v.1.5
- Board version 1.5
- 1.4 fixes
- v.1.5.1
- Line-out High freq. sigma-delta noise filter fix

Notice! This schematic matches board version 1.5

**VS1010Dev1\_51**

16.4.2019 14.56

Sheet: 1/3



VS23S040 is not populated on VS1010 developer board 1.5.  
Footprint is on the bottom side.

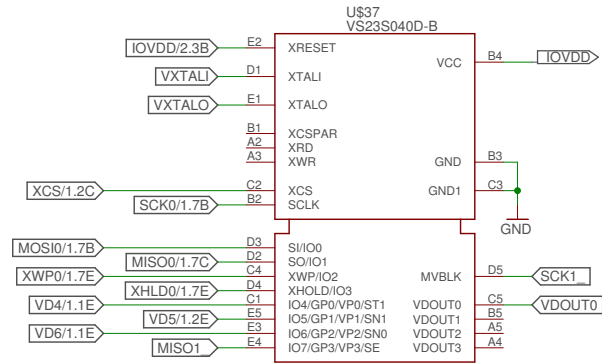

VS23S010 is populated on VS1010 developer board 1.5.  
The chip is on the top side.

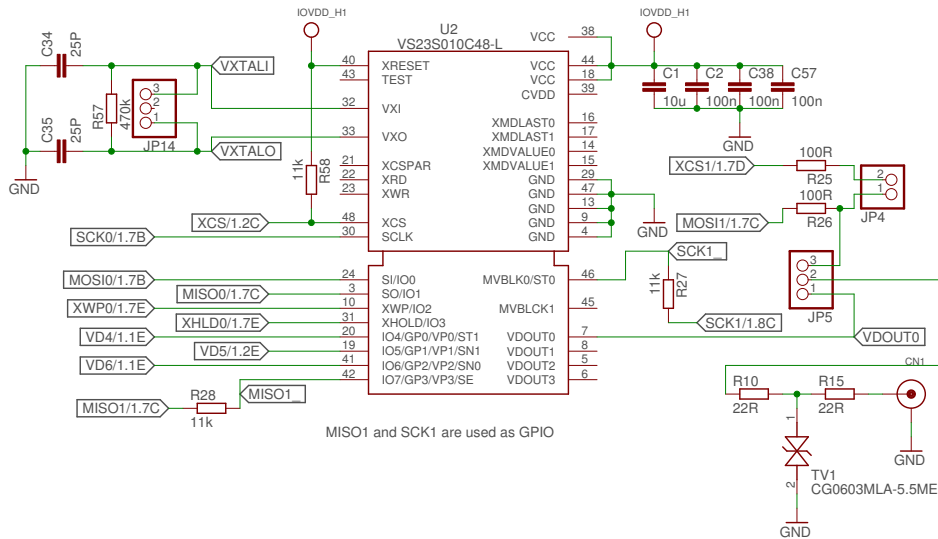

Only one of VS23S010 or VS23S040 may be populated.