

UNLESS OTHERWISE SPECIFIED:  
 ALL DIM IN MILLIMETERS.  
 GENERAL TOLERANCE AS  
 X.X = ±0.25  
 X.XX = ±0.13 ANGLES=±0.5°

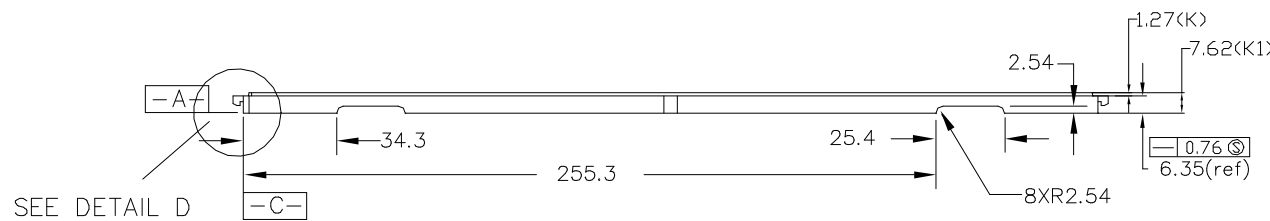
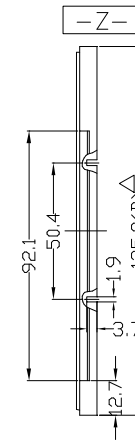
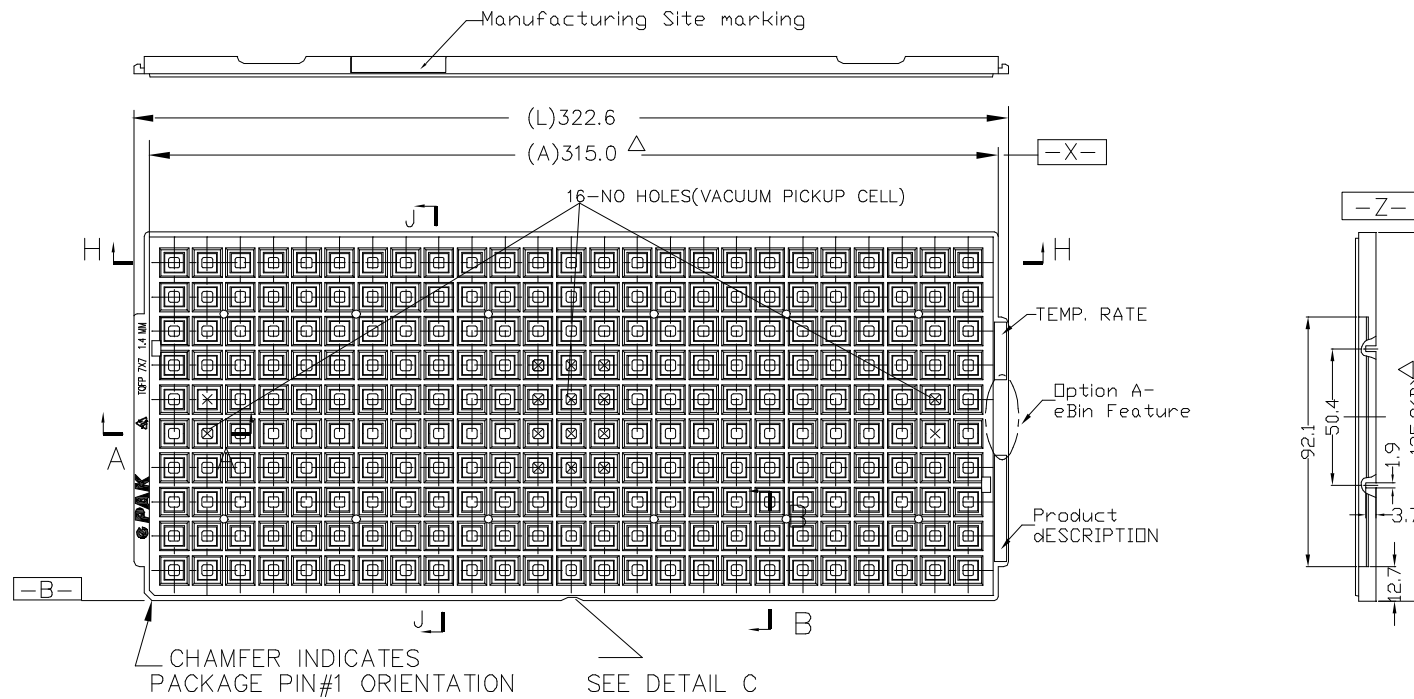

Copyright (c) 2003 e.PAK Resources (S) Pte Ltd. All rights reserved.

		PAGE 1 OF 3	DATE
P00813	Add notch	DRAWER: JACK LIU	03 DEC 01
P00496	New Format	ENG. REVIEWED: JOSEPH	03 DEC 01
P00428	Revise vaccum holes at both side	QA REVIEWED: GEORGE	03 DEC 01
P00387	ADD MATERIAL eP33	M/S REVIEWED: REBECCA	03 DEC 01
P00220	ADD MATERIAL eP20	PRD. REVIEWED: TAI	03 DEC 01
P00216	ADD MATERIAL eP22	APPROVED: MS KHOO	03 DEC 01
P00162	REVIEW DIM C1/C2 & FENCE HEIGHT		
ECN NO.	DESCRIPTION	DO NOT SCALE	

**ePAK** RESOURCES

CUSTOMER: ePAK

DESCRIPTION: eND 0707 1.4 1025 X R.A

DWG NO.	mTR0007	REV.	15
---------	---------	------	----

UNLESS OTHERWISE SPECIFIED:  
 ALL DIM IN MILLIMETERS.  
 GENERAL TOLERANCE AS  
 X.X = ±0.25  
 X.XX = ±0.13 ANGLES=±0.5°

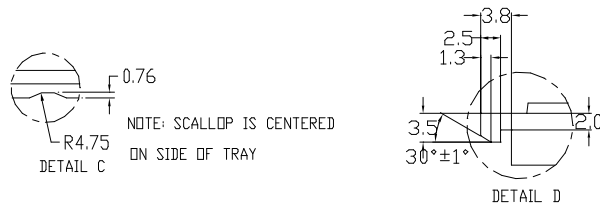
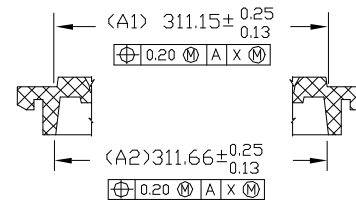
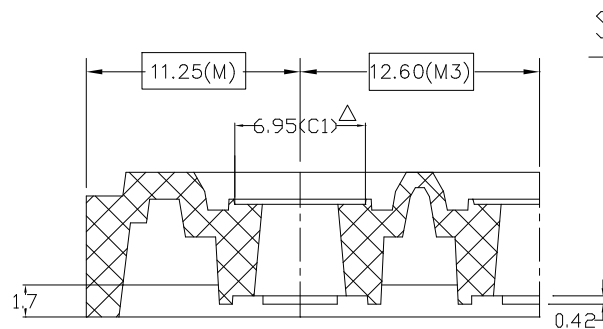
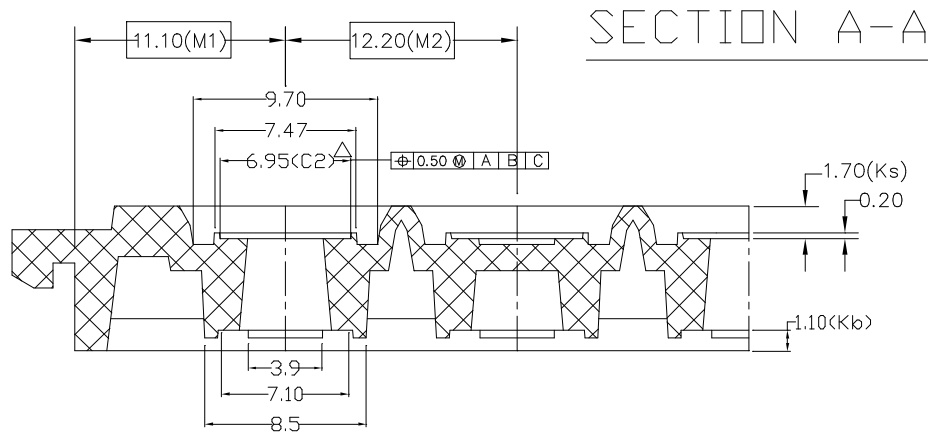

### SECTION H-H

### SECTION J-J

Copyright (c) 2003 e.PAK Resources (S) Pte Ltd. All rights reserved.

ECN NO.	DESCRIPTION	DO NOT SCALE	⊕	⊖
P00813	Add notch	DRAWER: JACK LIU	03 DEC 01	
P00496	New Format	ENG. REVIEWED: JOSEPH	03 DEC 01	
P00428	Revise vaccum holes at both side	QA REVIEWED: GEORGE	03 DEC 01	
P00387	ADD MATERIAL eP33	M/S REVIEWED: REBECCA	03 DEC 01	
P00220	ADD MATERIAL eP20	PRD. REVIEWED: TAI	03 DEC 01	
P00216	ADD MATERIAL eP22	APPROVED: MS KHOO	03 DEC 01	
P00162	REVIEW DIM C1/C2 & FENCE HEIGHT			

**ePAK** RESOURCES

CUSTOMER: ePAK

DESCRIPTION: eND 0707 1.4 1025 X R.A

DWG NO. mTR0007 REV. 15

PAGE 2 OF 3 DATE

UNLESS OTHERWISE SPECIFIED:  
 ALL DIM IN MILLIMETERS.  
 GENERAL TOLERANCE AS  
 X.X = ±0.25  
 X.XX = ±0.13 ANGLES=±0.5°

## PRODUCT DESCRIPTION AND TECHNICAL INFO.

MAT'L CODE	eP P/N	PRODUCT DESCRIPTION	TEMP. RATE	S.R(ohms/sq)Δ	Concavity/ConvexityΔ	Option A	Product Shipped
eP1	eTR0007-1-eB	eND0707 1.4 1025 1 R.A-eB	75 °C MAX	10 <sup>8</sup> - 10 <sup>11</sup>	0.45 Max	eBin Feature	
eP6	eTR0007-6-eB	eND0707 1.4 1025 6 R.A-eB	150 °C MAX	10 <sup>5</sup> - 10 <sup>11</sup>	0.45 Max	eBin Feature	
eP7	eTR0007-7-eB	eND0707 1.4 1025 7 R.A-eB	140 °C MAX	10 <sup>5</sup> - 10 <sup>11</sup>	0.45 Max	eBin Feature	
eP8	eTR0007-8-eB	eND0707 1.4 1025 8 R.A-eB	180 °C MAX	10 <sup>5</sup> - 10 <sup>11</sup>	0.45 Max	eBin Feature	
eP13	eTR0007-13-eB	eND0707 1.4 1025 13 R.A-eB	140 °C MAX	10 <sup>5</sup> - 10 <sup>11</sup>	0.45 Max	eBin Feature	
eP19	eTR0007-19-eB	eND0707 1.4 1025 19 R.A-eB	150 °C MAX	10 <sup>5</sup> - 10 <sup>11</sup>	0.45 Max	eBin Feature	
eP20	eTR0007-20-eB	eND0707 1.4 1025 20 R.A-eB	50 °C MAX	10 <sup>8</sup> - 10 <sup>11</sup>	0.45 Max	eBin Feature	
eP22	eTR0007-22-eB	eND0707 1.4 1025 22 R.A-eB	75 °C MAX	10 <sup>8</sup> - 10 <sup>12</sup>	0.45 Max	eBin Feature	
eP33	eTR0007-33-eB	eND0707 1.4 1025 33 R.A-eB	75 °C MAX	10 <sup>8</sup> - 10 <sup>12</sup>	0.45 Max	eBin Feature	
eP1	eTR0007-1	eND0707 1.4 1025 1 R.A	75 °C MAX	10 <sup>8</sup> - 10 <sup>11</sup>	0.45 Max	Non-eBin Feature	
eP6	eTR0007-6	eND0707 1.4 1025 6 R.A	150 °C MAX	10 <sup>5</sup> - 10 <sup>11</sup>	0.45 Max	Non-eBin Feature	←----
eP7	eTR0007-7	eND0707 1.4 1025 7 R.A	140 °C MAX	10 <sup>5</sup> - 10 <sup>11</sup>	0.45 Max	Non-eBin Feature	
eP8	eTR0007-8	eND0707 1.4 1025 8 R.A	180 °C MAX	10 <sup>5</sup> - 10 <sup>11</sup>	0.45 Max	Non-eBin Feature	
eP13	eTR0007-13	eND0707 1.4 1025 13 R.A	140 °C MAX	10 <sup>5</sup> - 10 <sup>11</sup>	0.45 Max	Non-eBin Feature	
eP19	eTR0007-19	eND0707 1.4 1025 19 R.A	150 °C MAX	10 <sup>5</sup> - 10 <sup>11</sup>	0.45 Max	Non-eBin Feature	
eP20	eTR0007-20	eND0707 1.4 1025 20 R.A	50 °C MAX	10 <sup>8</sup> - 10 <sup>11</sup>	0.45 Max	Non-eBin Feature	
eP22	eTR0007-22	eND0707 1.4 1025 22 R.A	75 °C MAX	10 <sup>8</sup> - 10 <sup>12</sup>	0.45 Max	Non-eBin Feature	
eP33	eTR0007-33	eND0707 1.4 1025 33 R.A	75 °C MAX	10 <sup>8</sup> - 10 <sup>12</sup>	0.45 Max	Non-eBin Feature	

- Notes: 1. No Manufacturing Site Marking for the products that ship to the Taiwan Region  
 2. "Δ" Marks indicate critical special characteristics

Copyright (c) 2003 e.PAK Resources (S) Pte Ltd. All rights reserved.

		PAGE 3 OF 3	DATE	 <b>RESOURCES</b>	
P00813	Add notch	DRAWER: JACK LIU	03 DEC 01		
P00496	New Format	ENG. REVIEWED: JOSEPH	03 DEC 01	CUSTOMER: ePAK	
P00428	Revise vaccum holes at both side	QA REVIEWED: GEORGE	03 DEC 01		
P00387	ADD MATERIAL eP33	M/S REVIEWED: REBECCA	03 DEC 01	DESCRIPTION: eND 0707 1.4 1025 X R.A	
P00220	ADD MATERIAL eP20	PRD. REVIEWED: TAI	03 DEC 01		
P00216	ADD MATERIAL eP22	APPROVED: MS KHOO	03 DEC 01	DWG NO. mTR0007 REV. 15	
P00162	REVIEW DIM C1/C2 & FENCE HEIGHT				
ECN NO.	DESCRIPTION	DO NOT SCALE	